

What's Happening in Application Development for iSeries

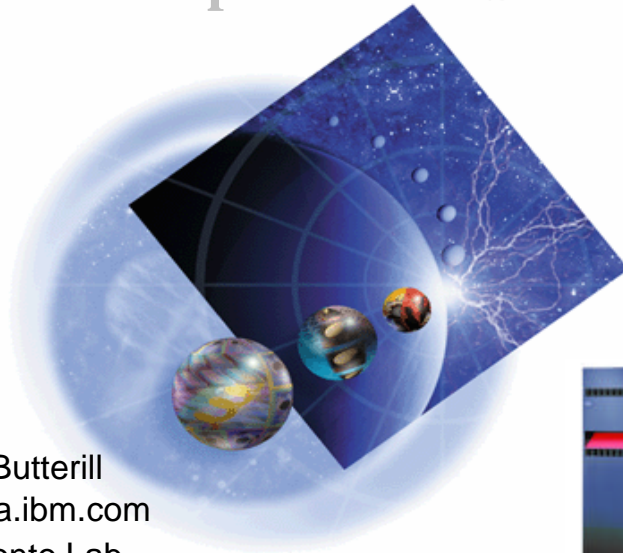

Alison Butterill
butteril@ca.ibm.com
IBM Toronto Lab
2000



Copyright IBM Corporation, 1999, 2000

Acknowledgement and Disclaimer

Acknowledgement:

Many people contributed to this presentation. In particular thanks goes to:
Phil Coulthard - IBM Toronto Laboratory

Disclaimer:

This presentation may contain examples of code and names of companies or persons. The code is given for presentation purposes and has not been tested by IBM. Therefore IBM does not guarantee the reliability, serviceability, or function of the code and the code is provided "AS IS". IBM EXPRESSLY DISCLAIMS ANY AND ALL WARRANTIES, INCLUDING BUT NOT LIMITED TO, THE WARRANTIES OF FITNESS FOR A PARTICULAR PURPOSE AND MERCHANTABILITY. Any names appearing in this presentation are designed to be fictitious and IBM makes no representations as to the accuracy of the names or data presented in accordance therewith.

Reproduction:

The base presentation is the property of IBM Corporation. Permission must be obtained PRIOR to making copies of this material for any reason.

Agenda

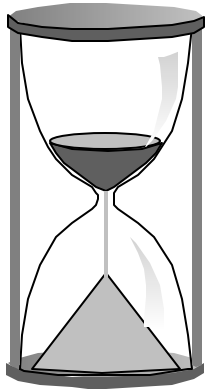

Industry Trends
Has the Tooling Kept Pace
What is the Strategy
Too Many Tools?
Thoughts for the Future

AD Business Environment

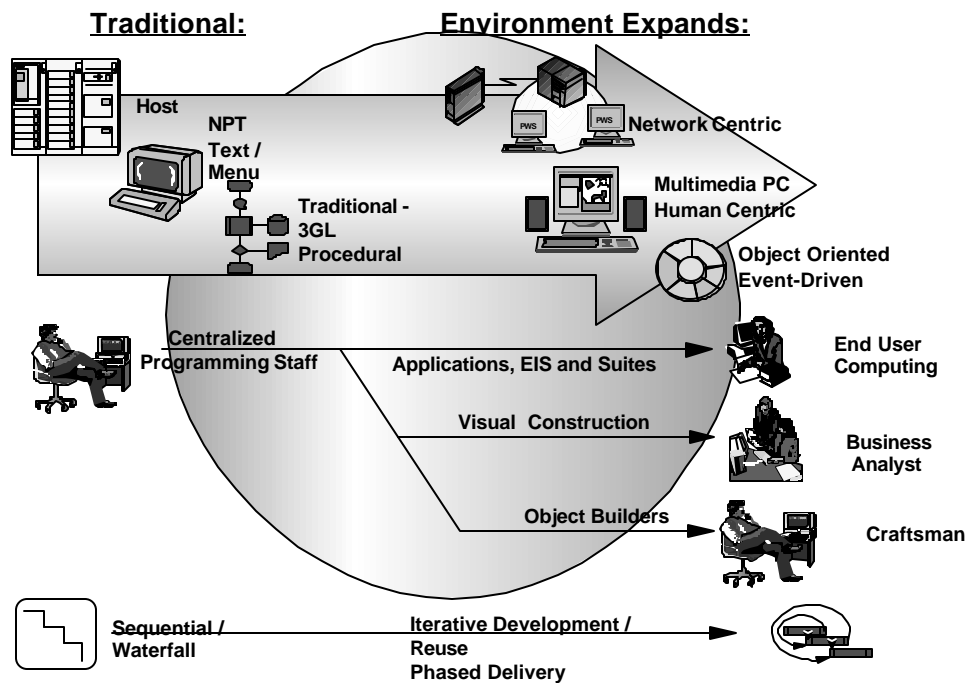

Technology Evolution

Top driving forces of AD Technology

1. Improve look and feel of applications
 - Cards and printers
 - External Display Files
 - User Interfaces - DSPFs to Full Interactive GUIs to PDAs
2. Improve internal architecture / re-usability of application code
 - Source code copying
 - Modularity (ILE) and OO principles
3. Improve productivity of programmers
 - Removing data descriptions from programs
 - OO, components, workstation-based tools, code-gen tools
4. Improve reach of applications
 - Through Web technologies

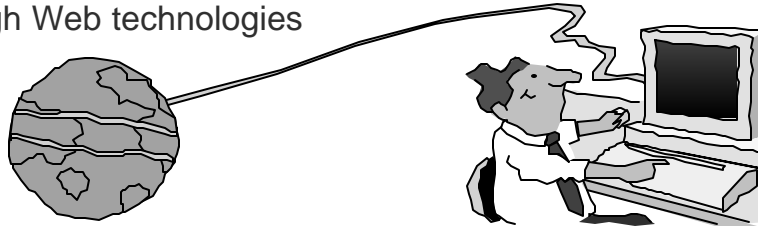

Copyright IBM Corporation 1999, 2000

AS/400e

Application Structure Evolution

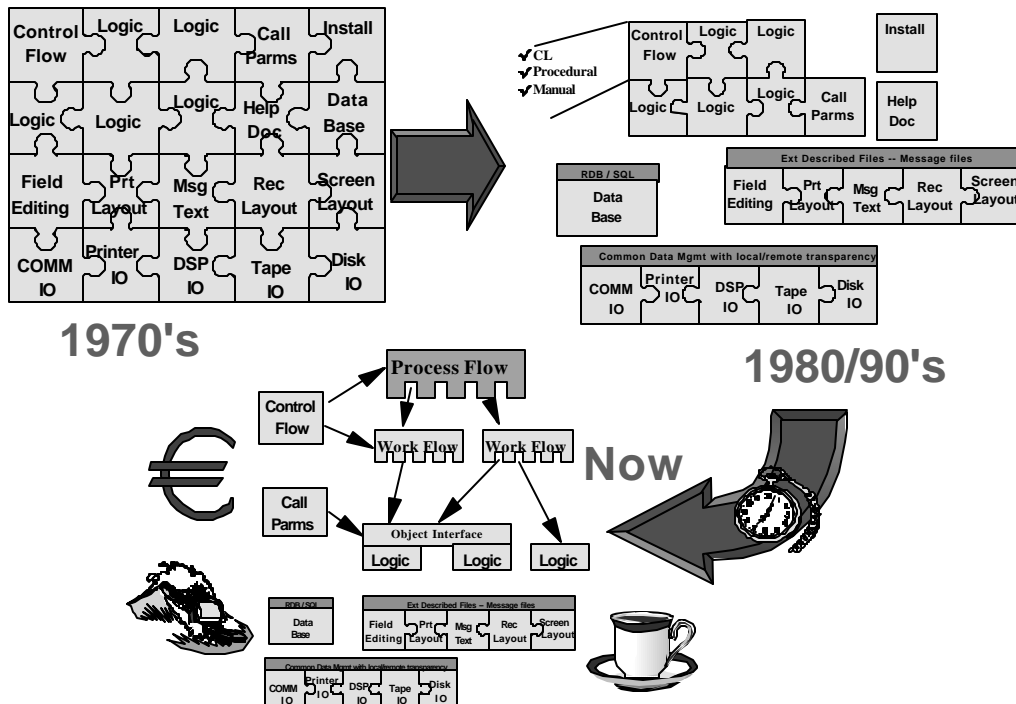

Copyright IBM Corporation 1999, 2000

AS/400e

Other Industry Trends

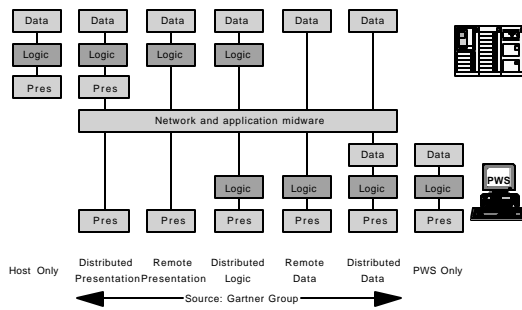

Client/Server

- = Provide GUI interfaces
- = Distribution of logic and data

CASE tools

- = Highly productive environment
- = Code consistency
- = Evolved from host/5250 based to Client/Server to Web enabled

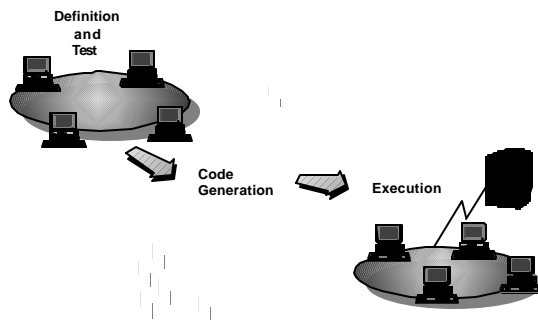

The Emergence of e-Business



- Universal access
- Standards

*Transforming the Way Key Business Processes are Done
by Using Internet technologies*



- Content/applications
- Core business processes
- Reliability, security, and availability



Web Presence ... History

Simple Web: - Static HTML

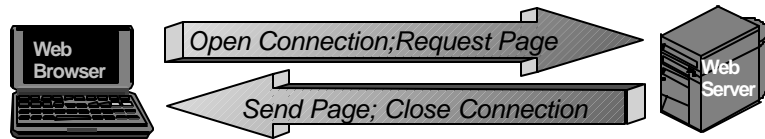

Interactive Web: - CGI-BIN on server

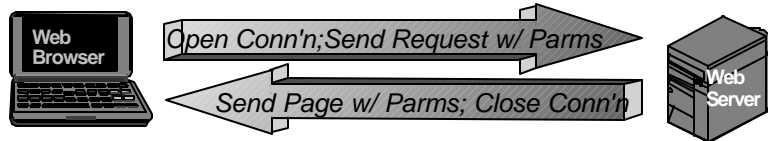

Distributed Web: - Java applets talk to server

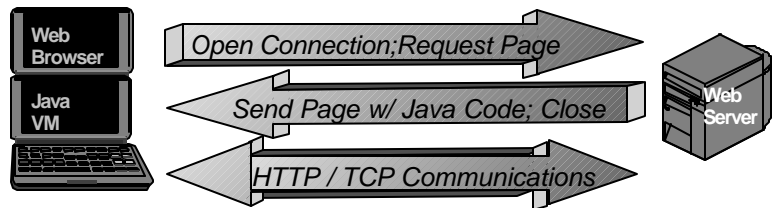

META Group Web Application Models
- Source: META Group

Copyright IBM Corporation 1999, 2000

AS/400e

AS/400 Toolbox for Java

Bridge from Java to AS/400 resources

- over 300 classes to use
 - data queues
 - database
 - message queues
 - program calls

Programs	Printers
Data	File System
Data Queues	Commands

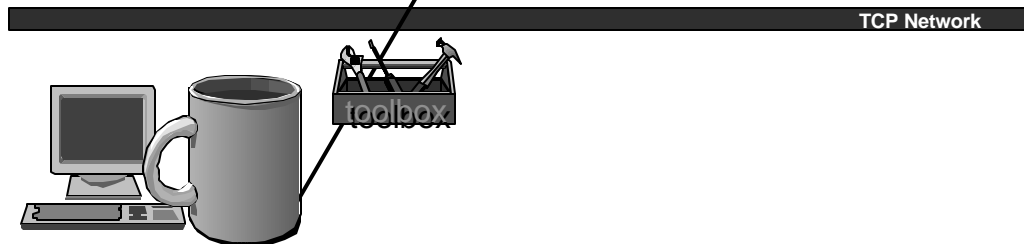

Copyright IBM Corporation 1999, 2000

AS/400e

JavaBeans

Simple yet powerful

- Compact, modular pieces of code
- Reusable
- Conform to published standards
 - properties
 - methods
 - events
- Portable

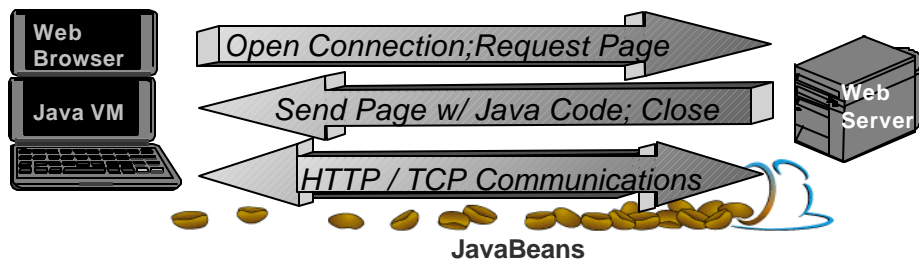

Server Java - iSeries

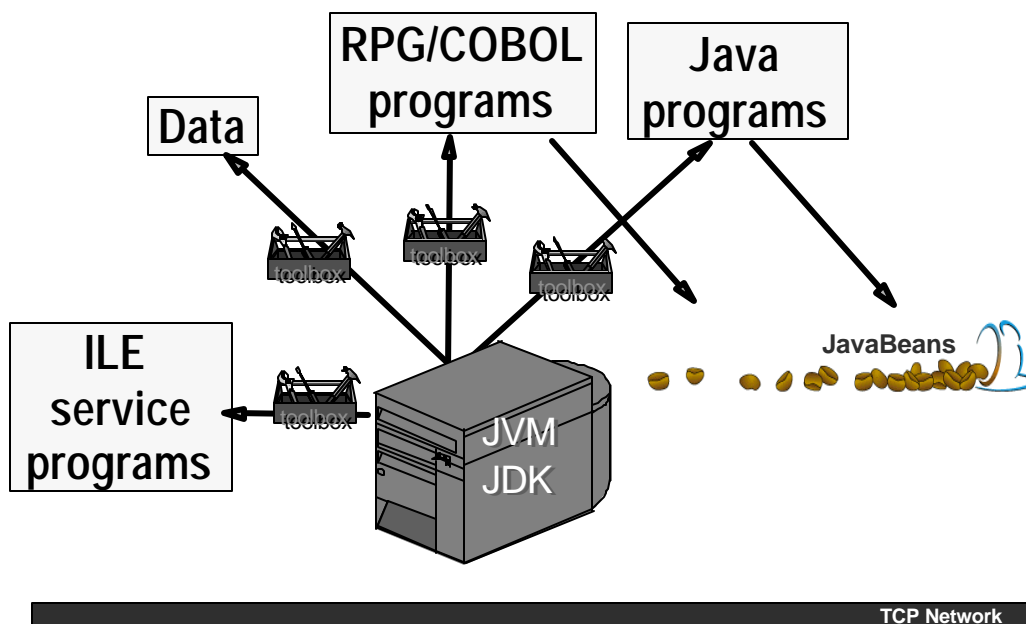

Servlets

Servlets offer a new UI option for the Web:

- keep logic on server
- send only HTML

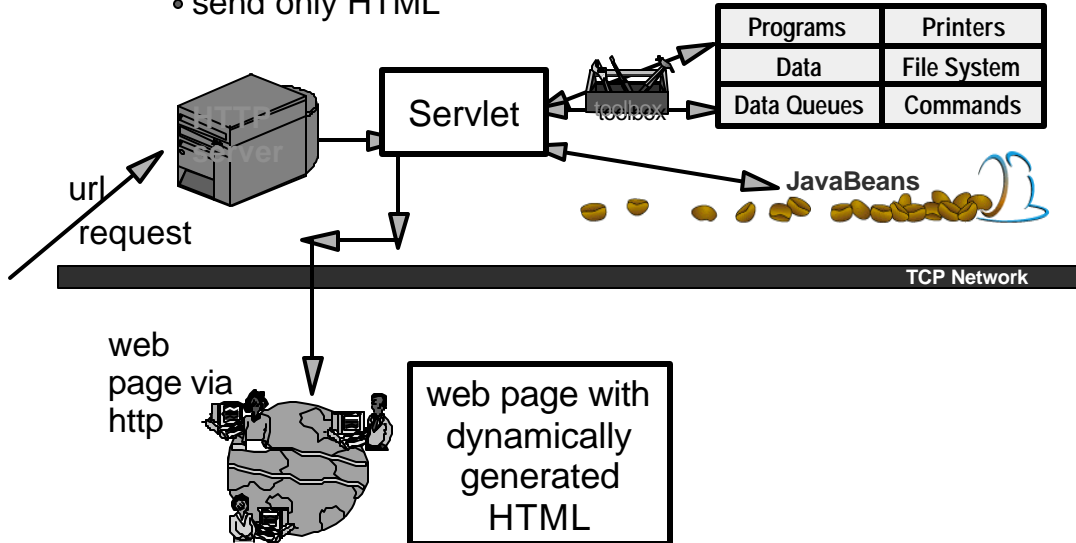

Java Server Pages

Separating user interface and logic!!

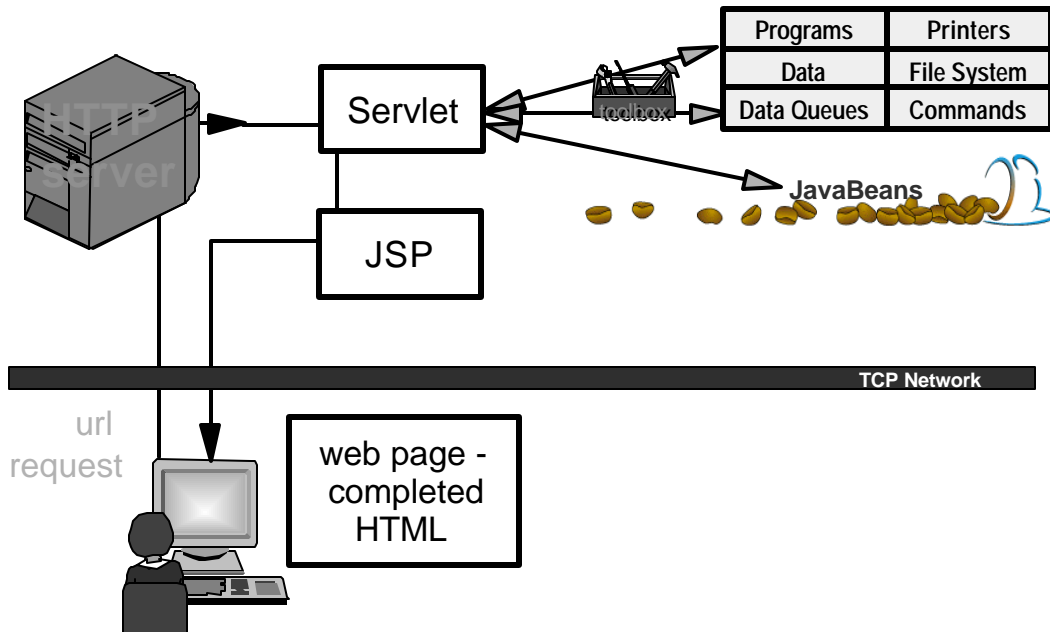

Servlet Server

Usually coupled with a Web server e.g. HTTP Server
 Manages and invokes registered servlets

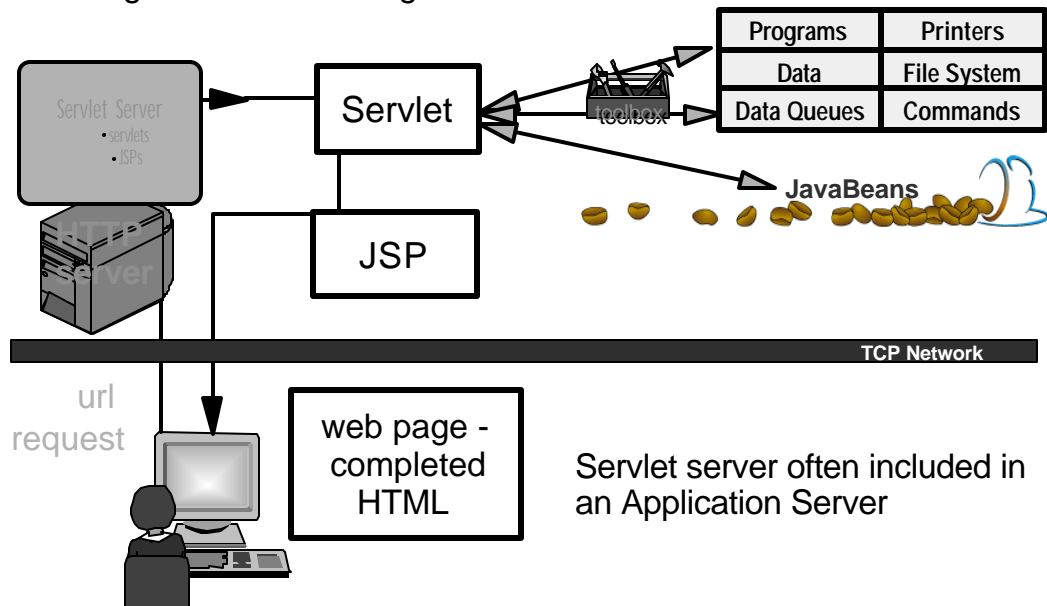

Servlet server often included in an Application Server

Enterprise JavaBeans - EJBs

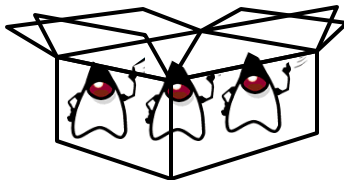

- Extends JavaBean model to support server components
- Differentiates between:
 - domain functionality (application programming)
 - java business logic
 - environmental infrastructure ("container")
 - transactions, security, naming
- Both logic and container must conform to specifications of the EJB model
- Need an EJB server
 - often included in an Application Server

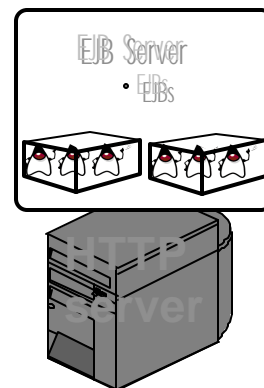

The eBusiness Technology of Today

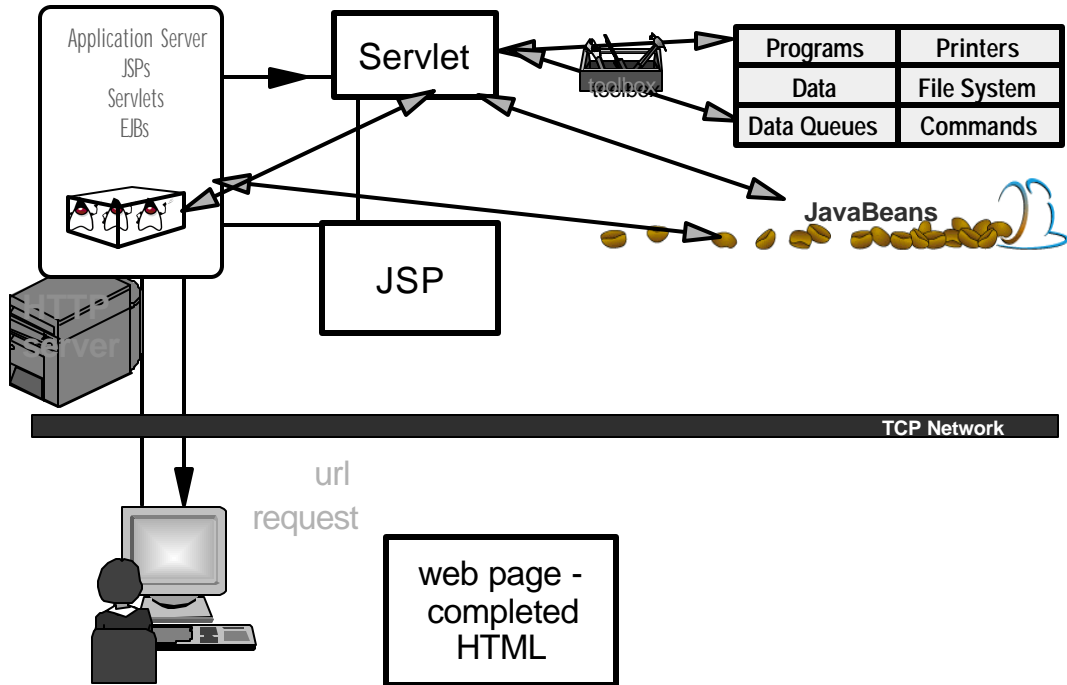

Has the Tooling Kept Pace?

The Last Decade

In the beginning there was...

- RPG/400, COBOL/400, Control Language (CL), Data Description Specifications (DDS)
- Programming Utilities
 - PDM - Program Development Manager
 - SEU - Source Entry Utility
 - SDA - Screen Design Aid
 - DFU - Data File Utility
 - System Debugger

The Last Decade

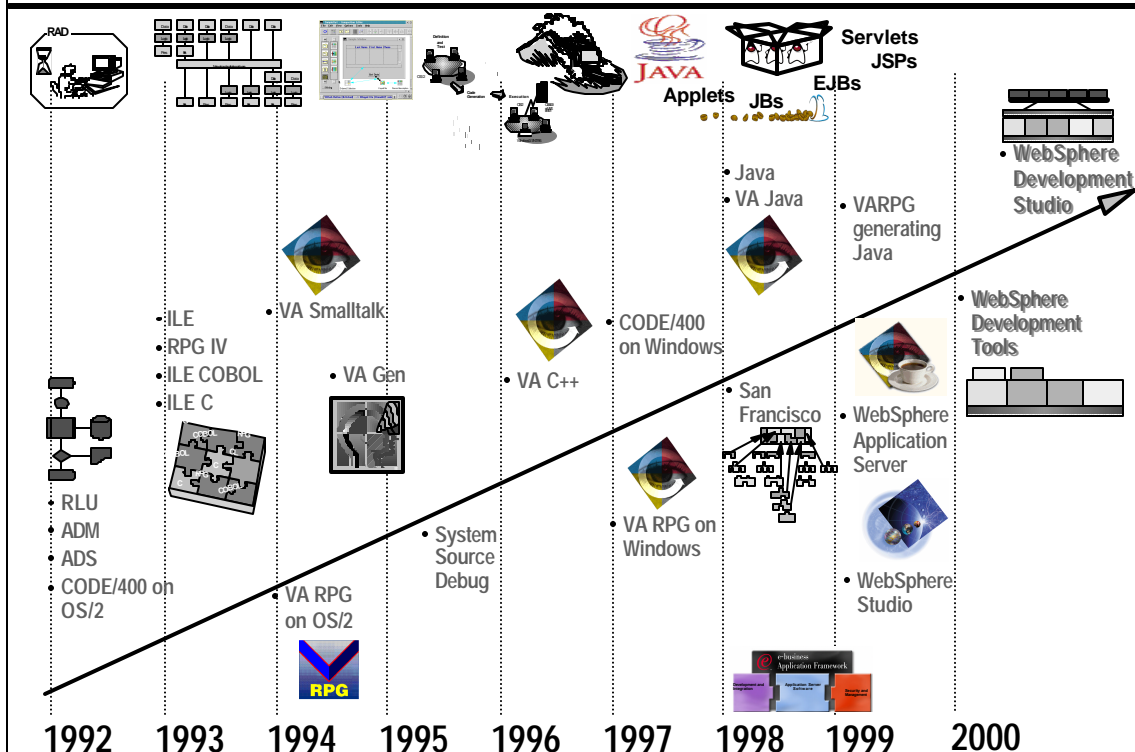

Traditional Languages - Recent Enhancements

RPG IV

- Interoperability with java
 - = JNI
 - = Thread Safety
 - = Direct Call Support
- New operations
 - Indicators
- Additional built-in functions
 - = testing logic within structure

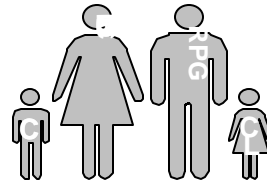

ILE COBOL

- Date and Time data types
- Interoperability with java
 - = Thread Safety
- Euro support

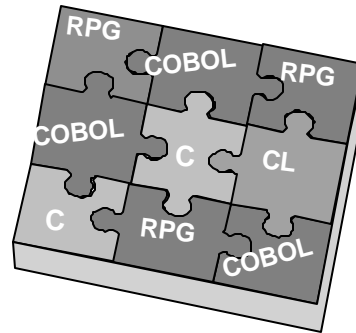

AD Tools: CODE/400

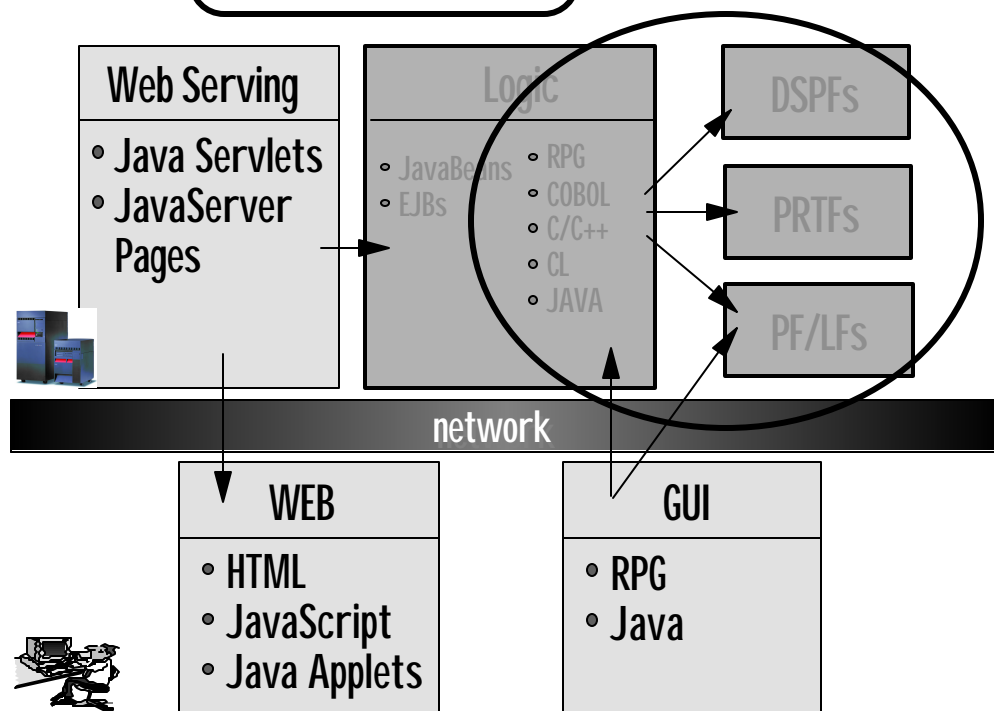

AD Tools: VARPG

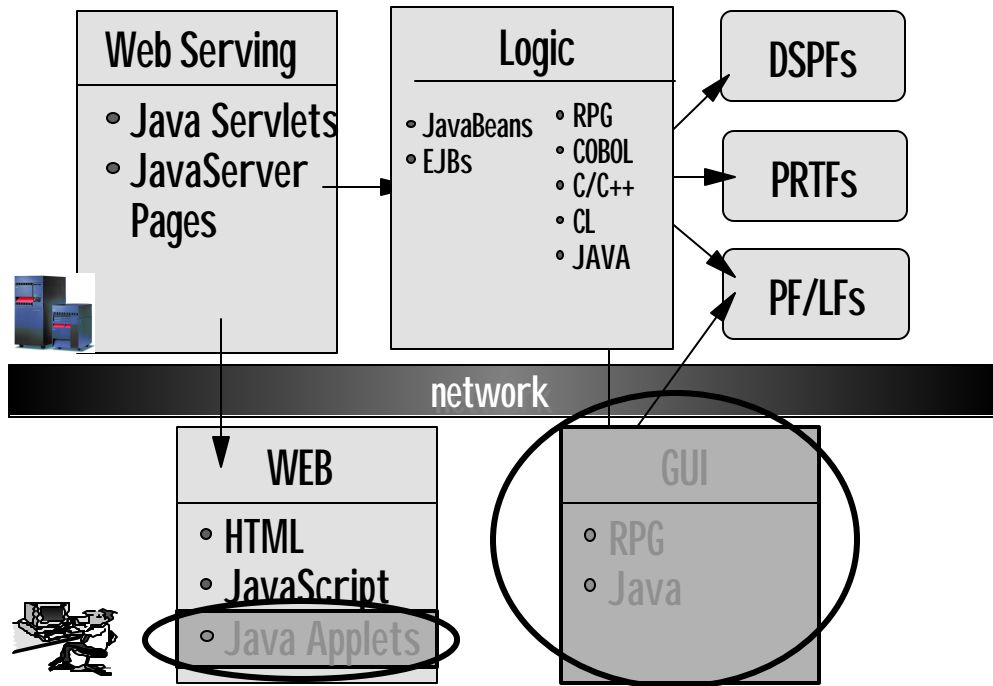

AD Tools: VAJava

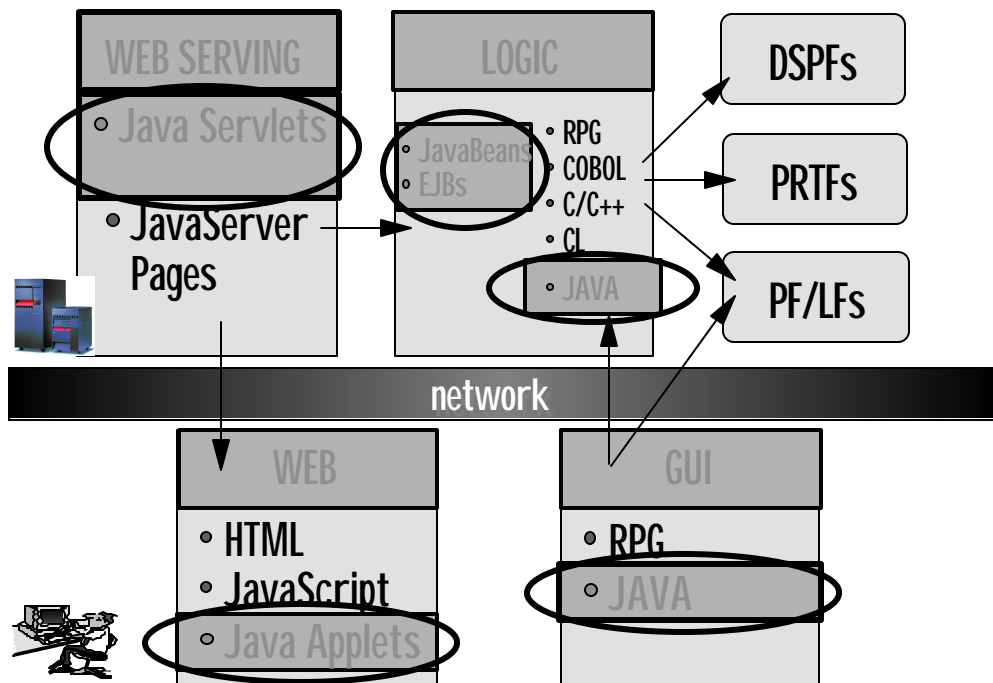

AD Tools: WebSphere Studio

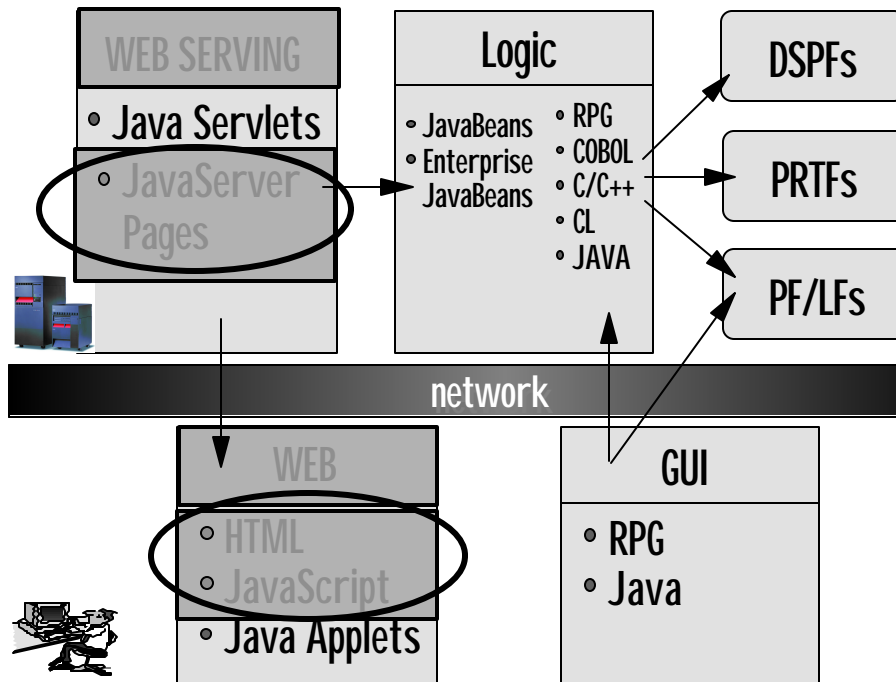

What is the Strategy?

eBusiness Application Models

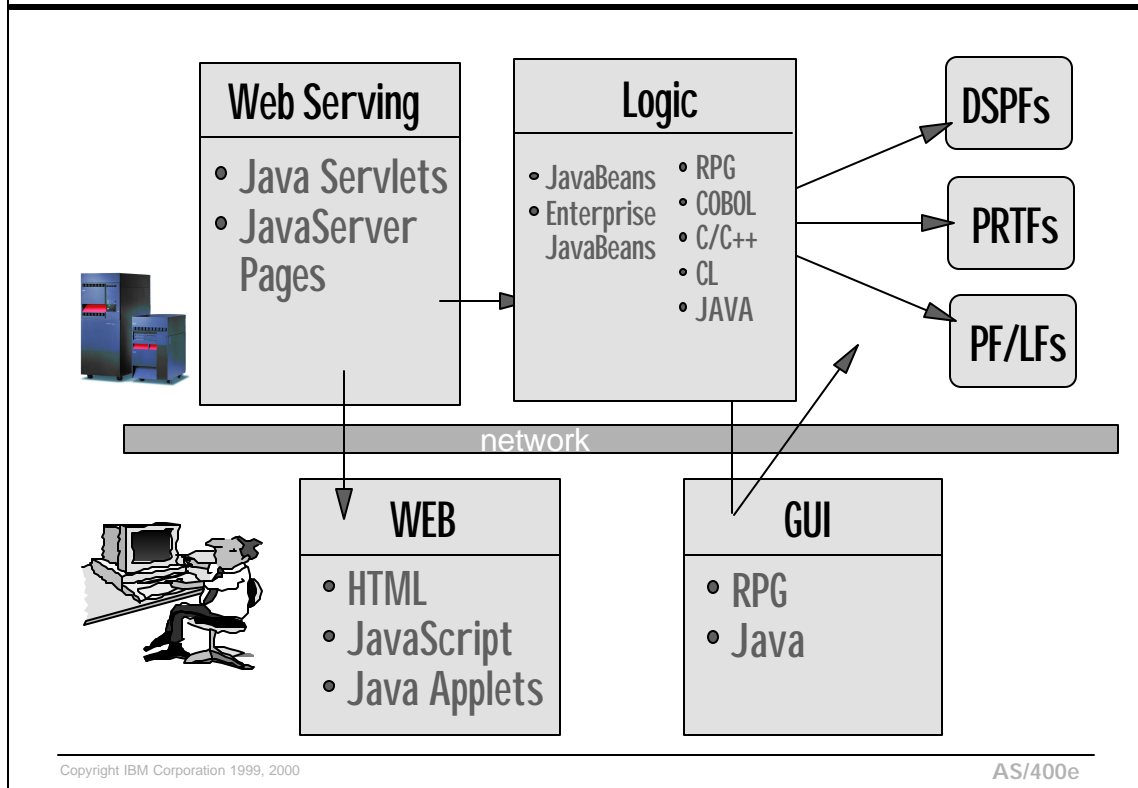

IBM's e-business Enablement Strategy

1 Extend Access of Core Business Processes and Apps to the Web

- HTML Web Connectors
- Java Clients (Connectors)
- Java Enterprise Access Builders (Connectors ++)

2 Build New e-business Logic on e-business App Servers that Extends Core Application Functionality

- Dynamic User Interaction (Servlets, JSPs)
- Extended Logic / Flow (Servlets, JavaBeans)
- Intelligent Data Services (XML)

3 Build New Transactional Logic on e-business App Servers

- Enterprise JavaBean Components
- Composed Business Objects

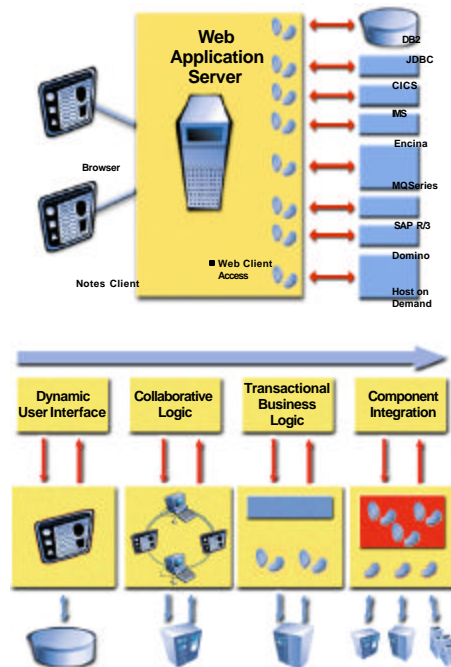

A Client to Services Framework for Building and Deploying Applications

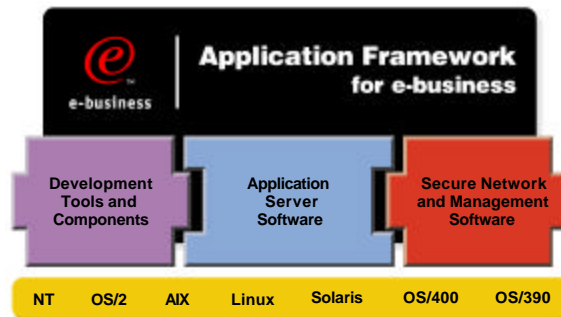

- Extends existing applications into the world of e-business
- Rapid application development environment based on cross-platform standards including Java
- Tested approach simplifies development, deployment
- Rich product portfolio supports simple to sophisticated applications
- Based on cross-platform standards (Java, XML, Servlets, JSPs, EJBs, ...)

The Runtime Environment

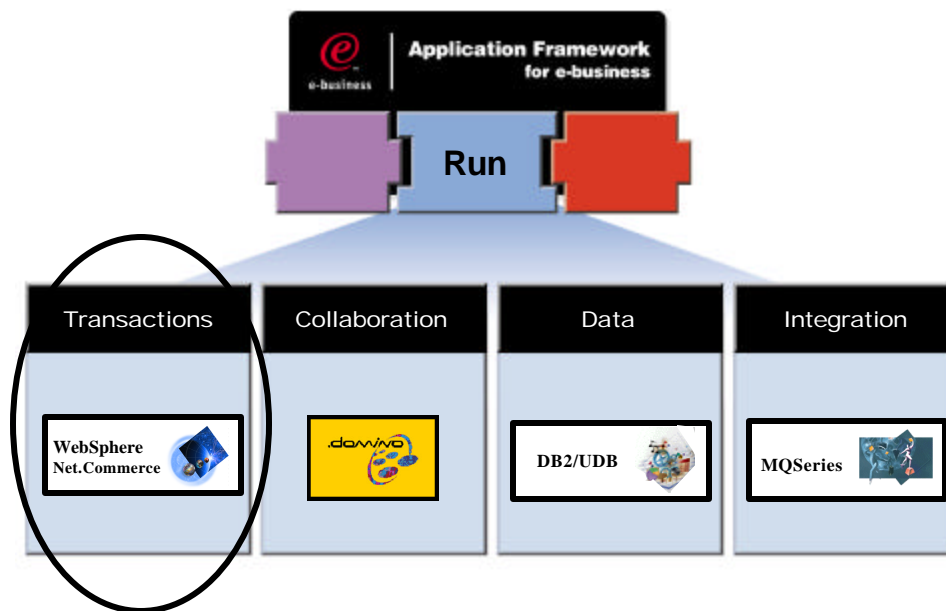

WebSphere Application Server

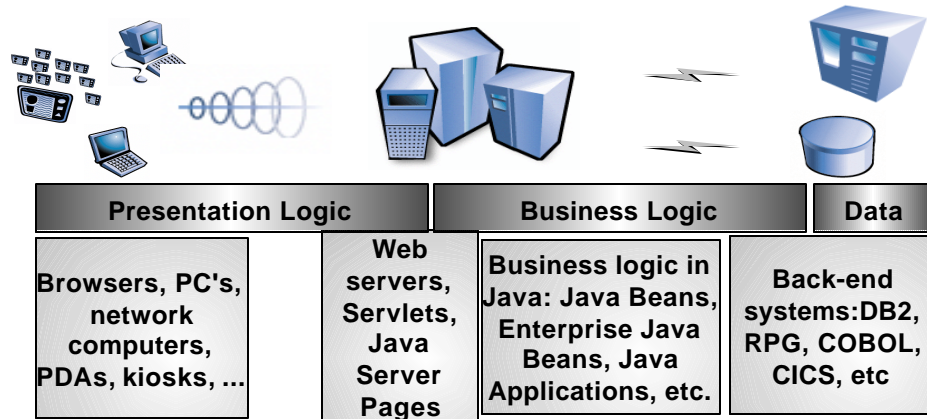

- WebSphere Application Server
 - Multi-platform: available on iSeries since V4R3 of OS/400
 - Standard Edition - Servlet Server (servlets and JSPs)
 - Advanced Edition - includes EJB Server also



WAS Standard Edition

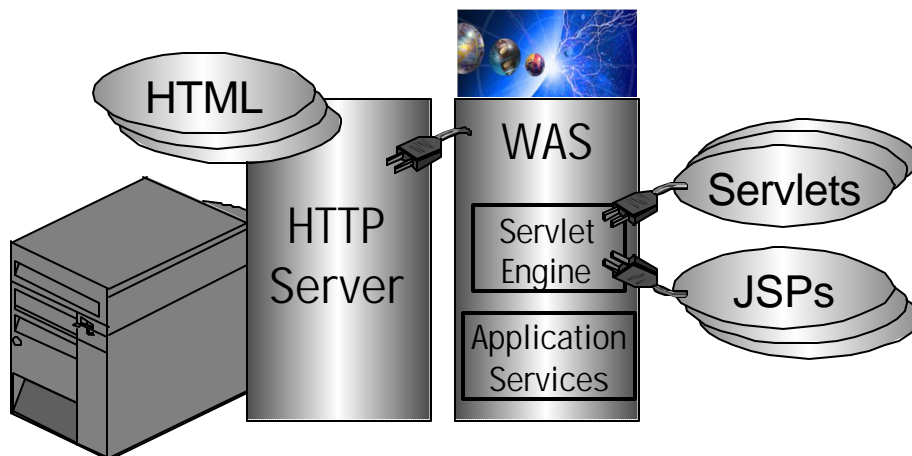

- HTML, Servlets, JSPs and all Java files exist in the Integrated File System (IFS)
- Use AS/400 Toolbox for Java to access DB2/400, RPG/COBOL, Data Queues, etc

WAS Advanced Edition

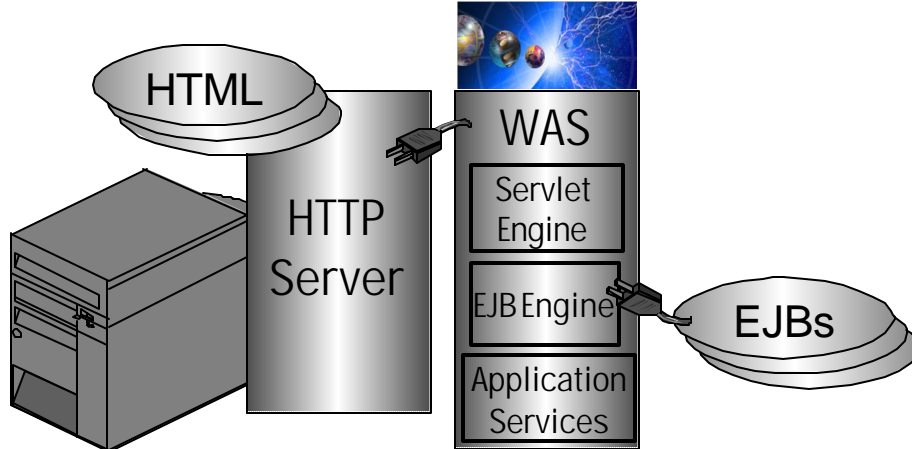

- HTML, Servlets, JSPs and all Java files exist in the Integrated File System (IFS)
- Use AS/400 Toolbox for Java to access DB2/400, RPG/COBOL, Data Queues, etc
- Provides the environment for setting up and managing Enterprise JavaBeans
- Containers created for holding the 'logic' functions

Too Many Tools!! Too Many Choices!!

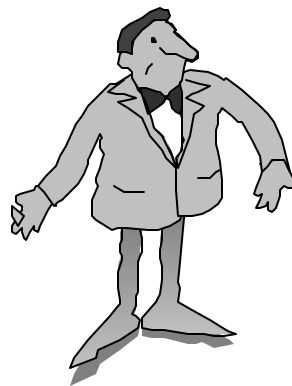

WebSphere Development Tools

for OS/400

Integrated Tool Offering

- tools to support all application models
- phased implementation

Phase 1 - Available October 20, 2000

Phase 2 - 2001

Phase 3 - ????

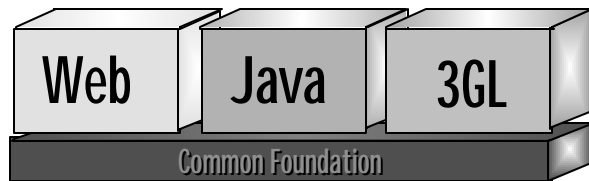
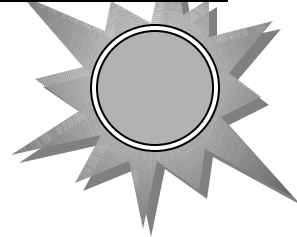

WebSphere Development Tools

• Client Tools Together

- CODE/400
- VisualAge RPG
- VisualAge for Java Professional + ET/400
- WebSphere Studio + AS/400 "Affinity"

Oct 20,
2000

Optionally purchase
VAJava EE for EJB
Tooling

• Add Additional Functionality

- Business Partner "Early Adopter" DSPF to Web conversion (WebFacing) program

4Q,
2000

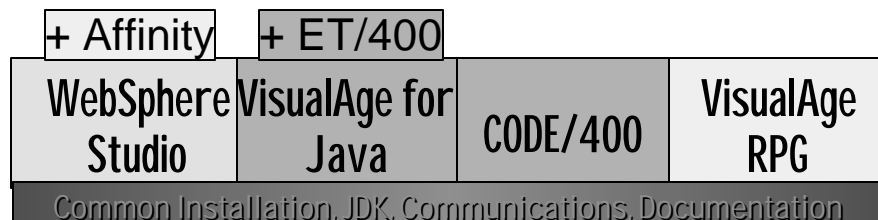

What Is WebFacing?

- WebFacing is technology to run green-screen applications on the Web
 - Part 1: A DSPF DDS to JSP conversion
 - Part 2: A runtime intercept
- Goals of WebFacing:
 - Quickly web-enable many applications
 - Allow iterative optimization for the Web

WebFacing - Before and After

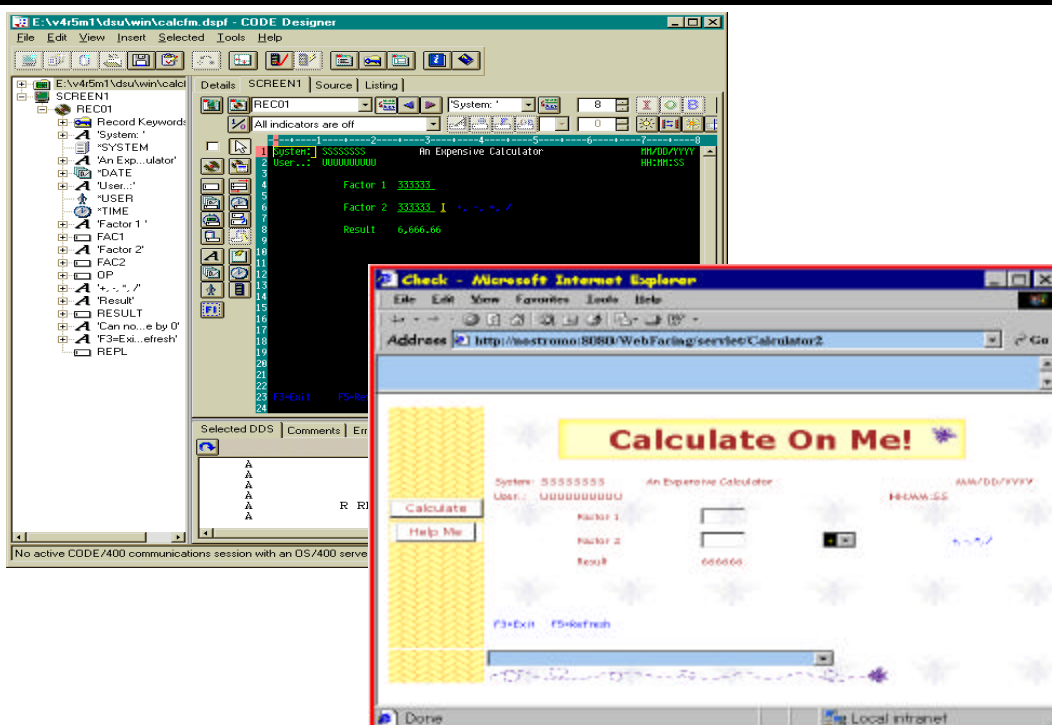

Websphere Development Studio (Phase 2)

Statement of Direction

- All Tools Together

- Client Tools (including GA of WebFacing)
- ADTS (PDM, SEU, SDA, RLU, DFU, AFP, CGU)
- RPG and COBOL
- C and C++

2001

- Add "Open" IDE (*Workbench*)

- Common launch pad for all tools, any tool
- Common project definition and maintenance

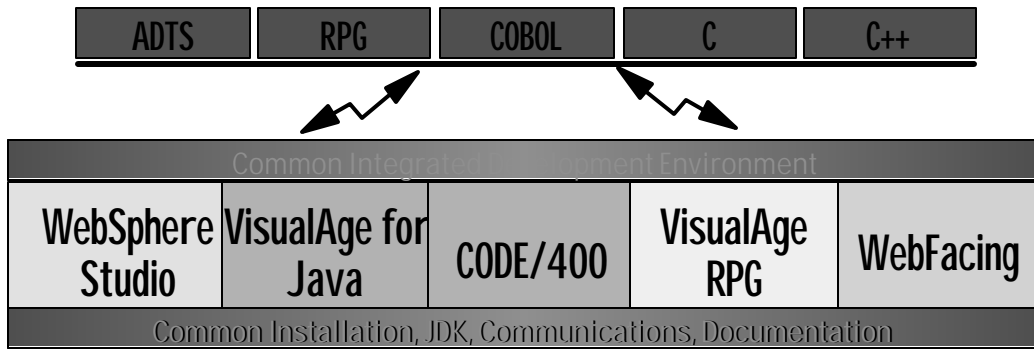

Copyright IBM Corporation 1999, 2000

AS/400e

Phase 2 IDE

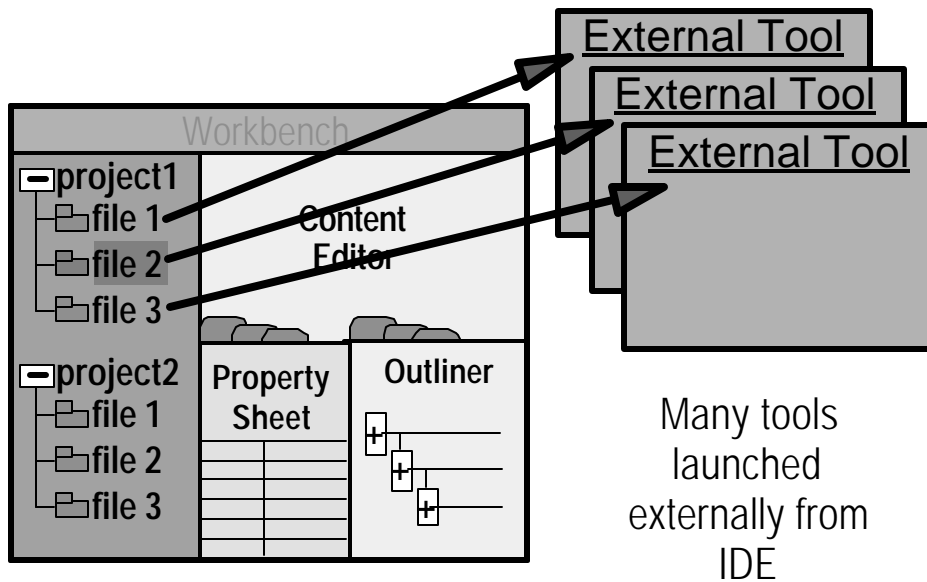

Copyright IBM Corporation 1999, 2000

AS/400e

Phase 3 IDE - All Powerful IDE

FUTURE

- Evolve all IBM client products into panes within the IDE
- Become "built-in" Workbench tools, versus separately launched products
- Steadily increase IDE tool portfolio
- IBM common tool components
 - 3rd party tool components
 - Customer authored tools

Statement of Direction!
▸ *Subject to change*

Phase 3 IDE

FUTURE

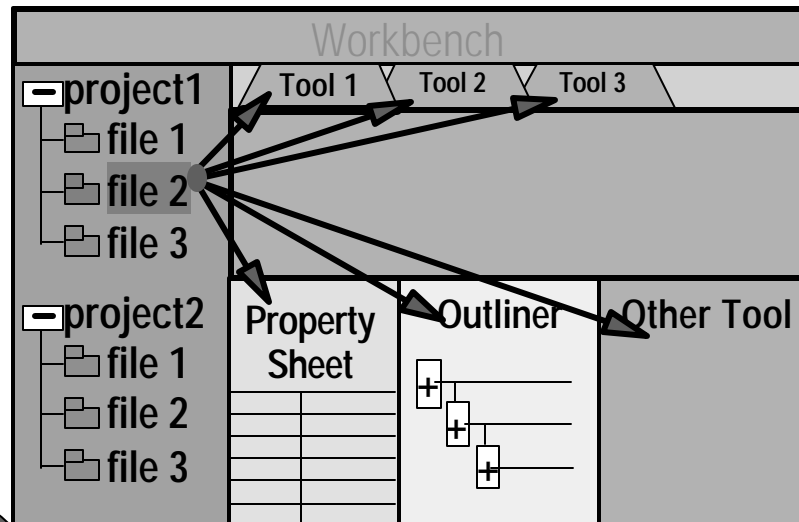

Statement of Direction!
▸ *Subject to change*

✓ All tools internal to IDE

Thoughts for the Future??

WebSphere App Server vs Domino

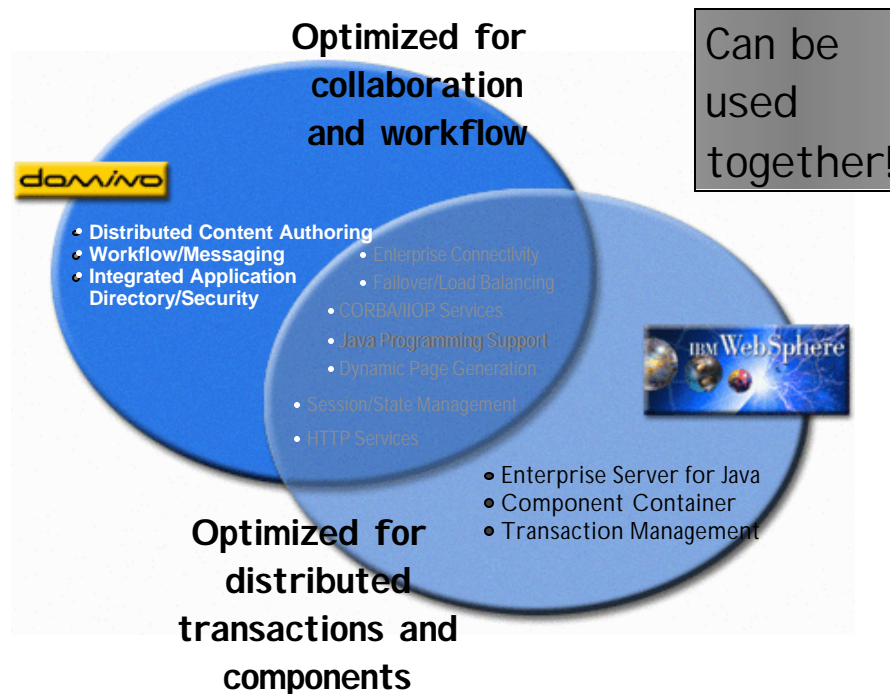

Forces of Change

Integration

- Fewer and fewer separate AD Tools

Much focus on eBusiness

- Business to customer
- Business to business
- Customer to customer?

Role based development

- Tooling will target individual roles
- Designer, developer, deployer, etc

Integrated Roles-Based Development

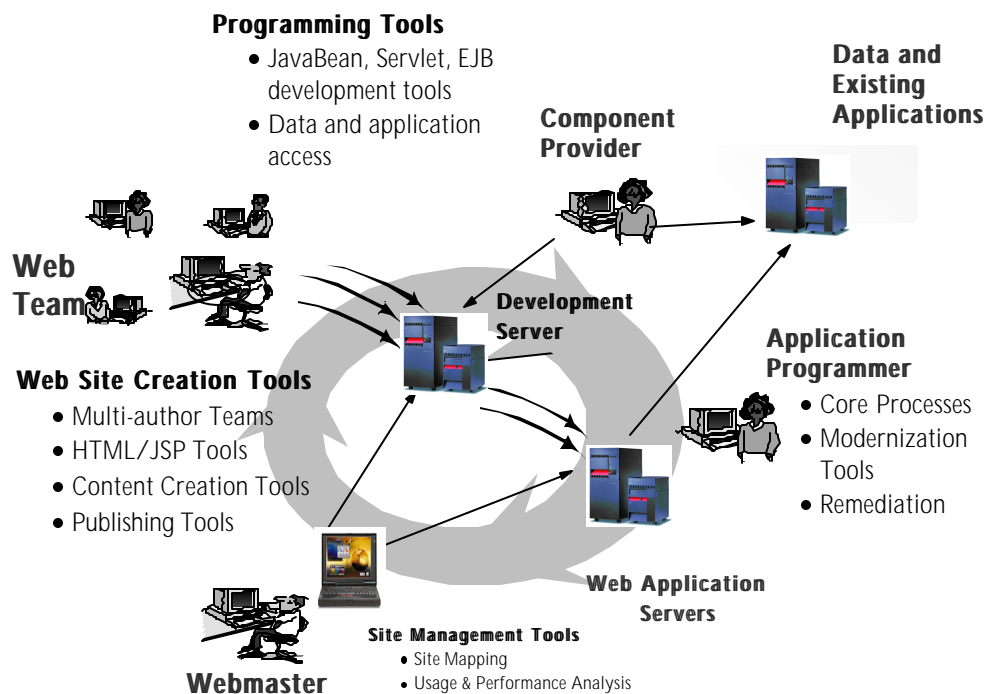

Forces of Change

Servlets and JSPs

- Will evolve into preferred UI option
- Tools and runtimes will mature

Pervasive Computing

- Held-hands and mass consumer devices will become next UI

XML

- Will permeate AD
 - EG: XML will become format for expressing data

Linux will become more popular

References

Need More Information??

www.ibm.com/software/ad

www.ibm.com/software/ad/wdt400

